

Vapor Eliminator Level Controller

Operational Manual

For Models
370 & 372



370 Series

Fuel Measurement Accessories

INSTRUCTION MANUAL

370 Series Fuel Metering Accessories

TABLE OF CONTENTS

370 Series

Vapor Eliminator

General Description/Specifications page 3

Vapor Eliminator – Drawings page 5

Vapor Eliminator – Performance Curves page 6

Level Controller

General Description/Specifications page 7

Level Controller – Drawings page 8

Level Controller – Performance Curves page 9

372 Series

Vapor Eliminator and Level Controller

General Description/Specifications page 10

Sectional Drawing page 12

Performance Curves pages 12-13

Model 370

Vapor Eliminator – General Description/Specifications

The Vapor Eliminator is an in-line self-venting chamber which is used in both portable and stationary Max fuel-measurement systems. It is placed directly upstream of the flowmeter- separating gases resulting from the “boiling” of low vapor pressure fuels, and removing air bubbles resulting from aeration of the fuel tank, or leaks on the suction side of the pump. It ensures that the flowmeter measures liquids only.

Specifications

Materials of construction:

Body	303 Stainless
Valve Orifice	303 Stainless
Valve Seal	Special Nitrile
Float	304 Stainless
Miscellaneous Levers	304 Stainless
Screens	304 Stainless

Volume (approximately) 202 cc's

Maximum Inlet Flow rate (liquid plus entrained gases)*

Gasoline	5250 cc/min
Alcohol	4375 cc/min
Diesel	3500 cc/min

Maximum Operating Pressure 100 psi

Supply Line Size 1/4" or 3/8" tubing

Maximum Temperature of Fuel

Gasoline	130°F
Alcohol	140°F
Diesel	200°F

* NOTE: Flow rates approaching the maximum of the Inlet Port will reduce the vapor elimination capabilities.

Model 370 Vapor Eliminator – Application Description

The diagram below shows the arrangement of components in a typical fuel-measurement system. Note the proximity of the vapor eliminator to the flowmeter. Note that the vapor vent line returns to the fuel tank; merging with the vent line of the level control tank is an acceptable practice.

The Level Controller stores return fuel from the engine's fuel injectors or carburetor and is replenished by fuel passing through the flowmeter. The controller operates at atmospheric pressure and will present no back pressure to the return fuel line. Vapor elimination of this fuel is also accomplished by the controller's internal screens.

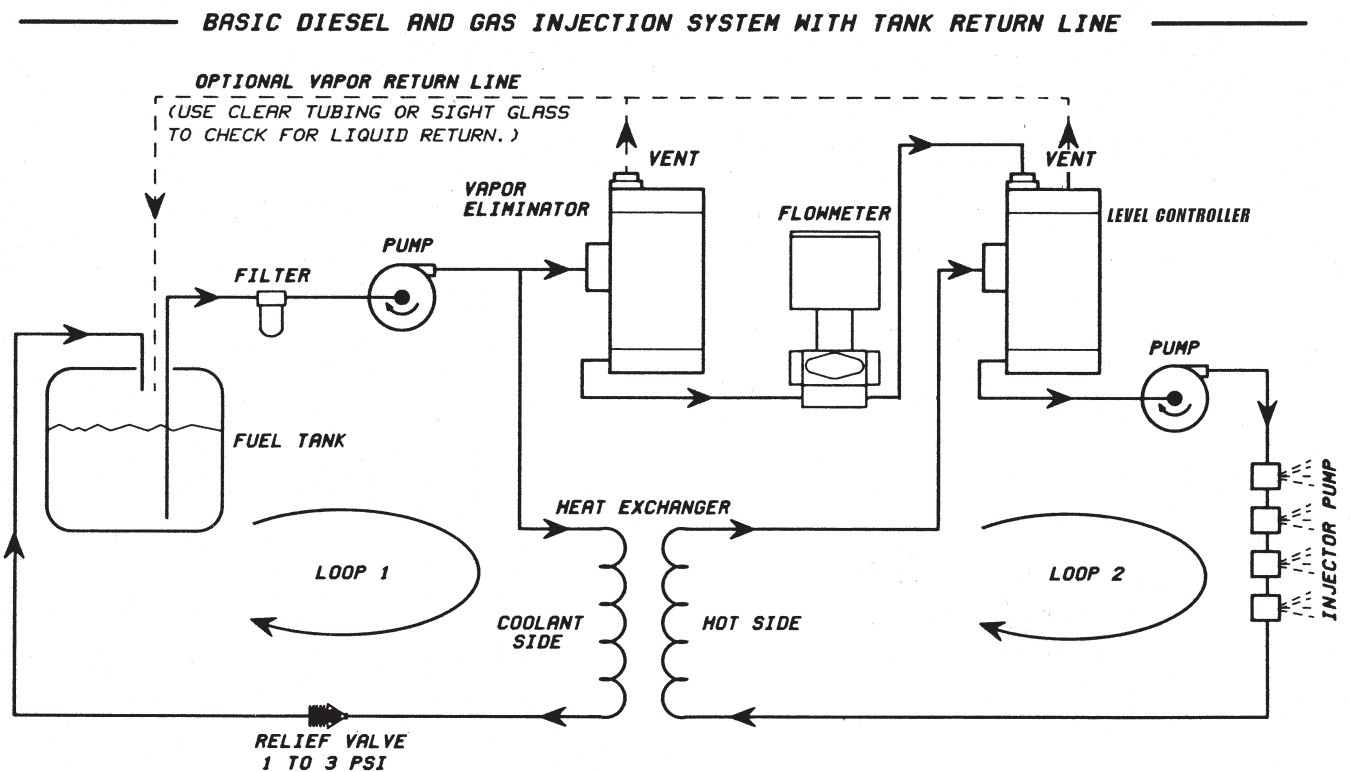

Model 370 Vapor Eliminator – Drawings

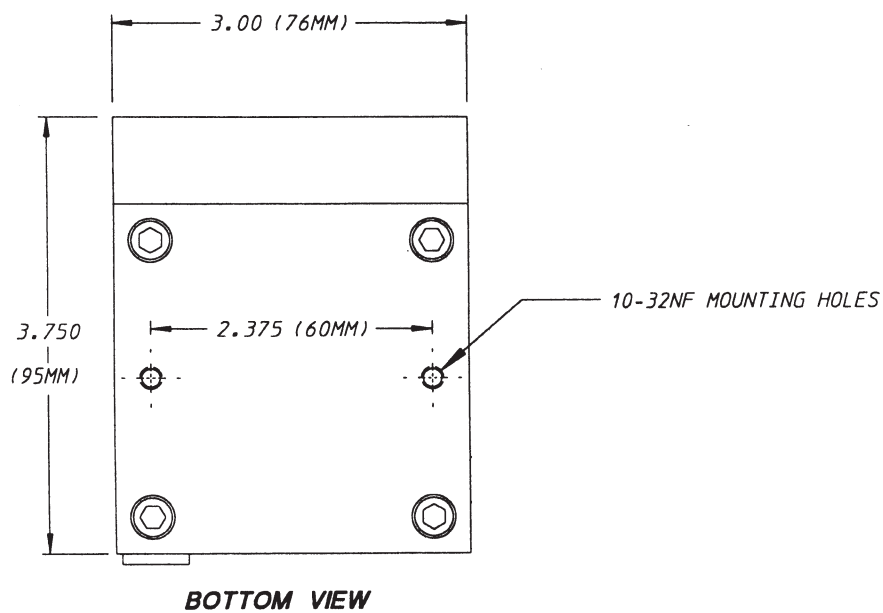
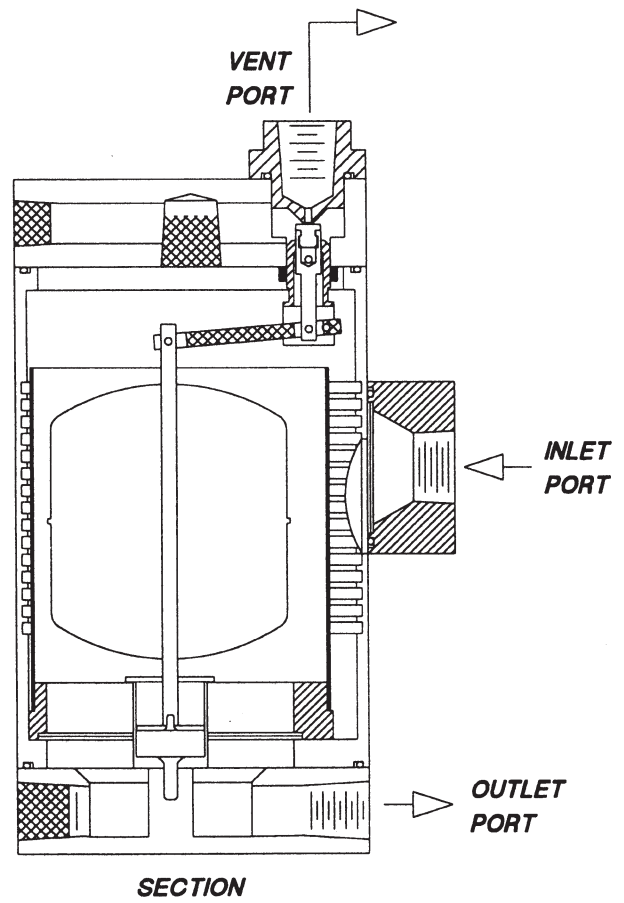
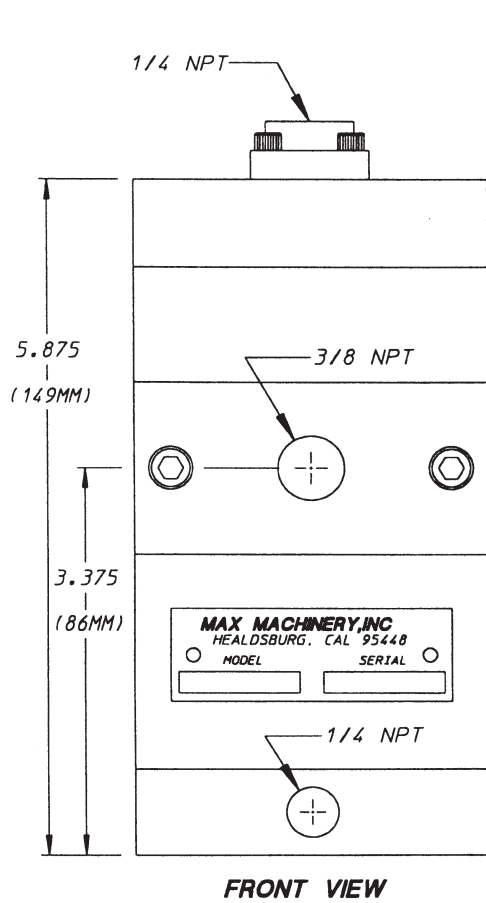

Model 370 Vapor Eliminator – Performance Curves

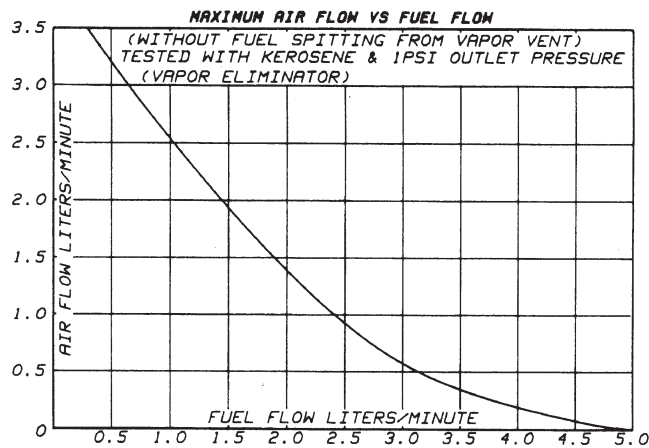
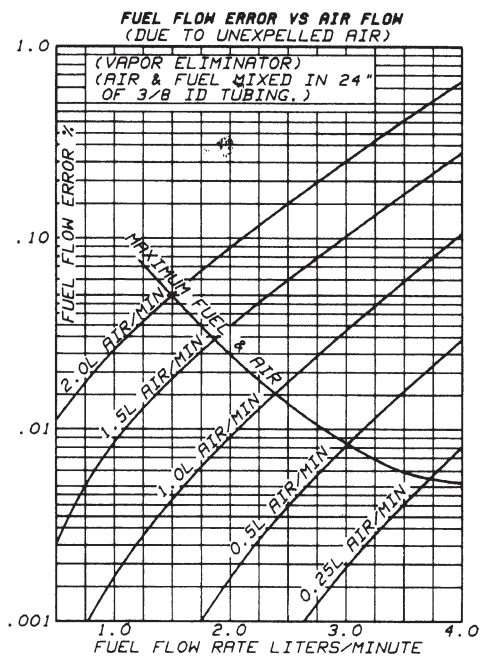
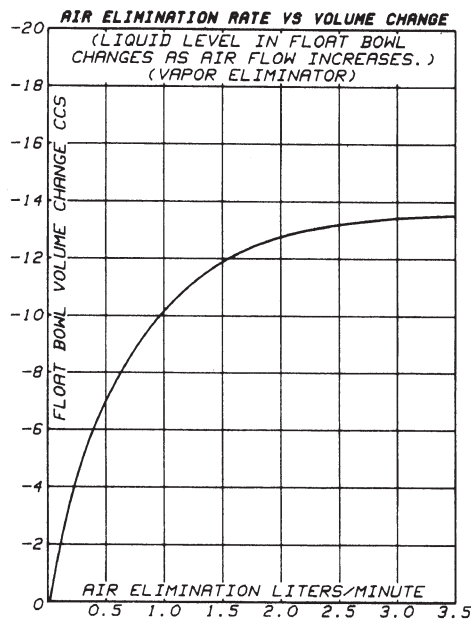
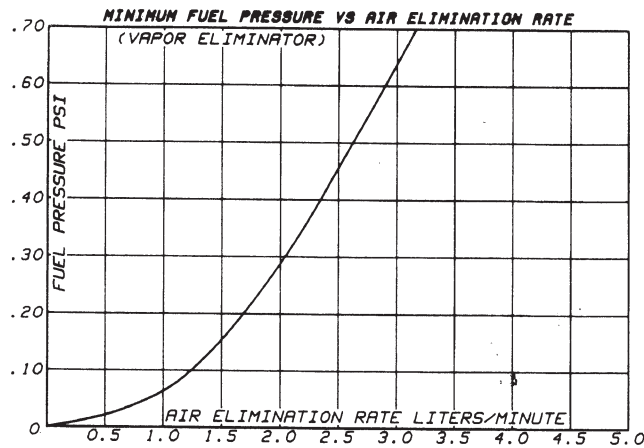

Model 370

Level Controller General Description/Specifications

Specifications

Materials of Construction:

Body	303 Stainless
Valve orifice	303 Stainless
Valve Seal	Special Nitrile
Float	304 Stainless
Miscellaneous Levers	304 Stainless
Screens	304 Stainless

Maximum Fuel Flow Rate

Inlet Port (no vapor)*

Gasoline	2200 cc/min
Alcohol	2000 cc/min
Diesel	1500 cc/min

Return Port (< 1000 cc/minute vapor)*

Gas	3000 cc/min
Alcohol	2500 cc/min
Diesel	2000 cc/min

Supply Port

This is the tank outlet. The fuel drawn from the tank must not exceed the sum of the inlet port flow, and return port flow.*

Maximum Inlet Fuel Pressure	20 psi
Volume (w/10 psi supply)	202.1 cc

Maximum Temperature of Fuel

Gasoline	130°F
Alcohol	140°F
Diesel	200°F

*NOTE: Flow rates approaching the maximum of either the Inlet Port or the Return Port will reduce the vapor elimination capabilities.

Level Controller – Application Description

The Max Level Controlled recirculation tank performs two basic functions: The recirculation tank function provides the engine with a source of fuel and allows unburned return fuel to flow back to a tank which is at atmospheric pressure. The tank is open to the atmosphere to eliminate back pressure on the engine's fuel system as well as to vent bubbles removed from the fuel. The tank is outfitted with a series of screens to collect the entrained vapor that often results from the mechanical action of the injector and/or heating of the fuel. These bubbles rise to the surface, while the engine is supplied with bubble-free fuel from the lowest port.

The level control function automatically feeds measured make-up fuel into the recirculation tank to replenish the fuel consumed by the engine. A float activated valve is used to maintain a consistent tank level. The valve opening is varied to regulate the flow of pressurized fuel into the tank typically through a flow meter (see page 4).

Model 370 Level Controller – Drawings

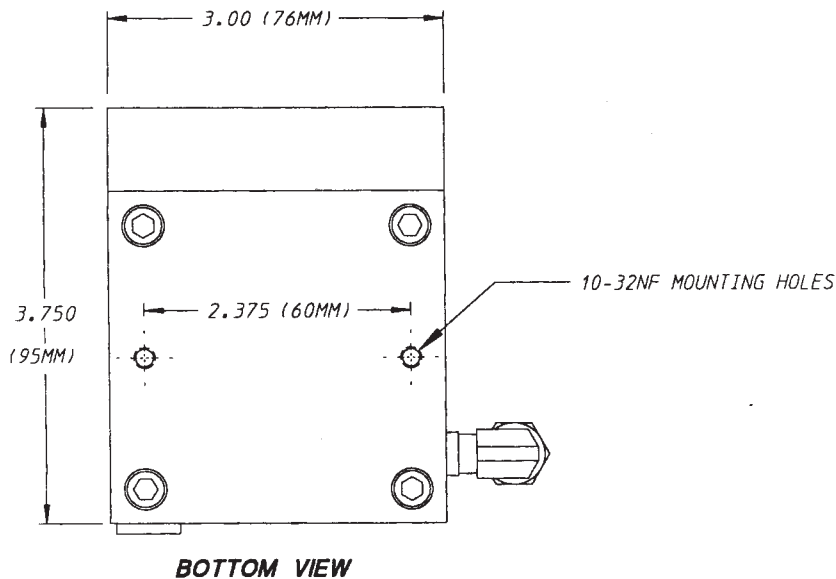
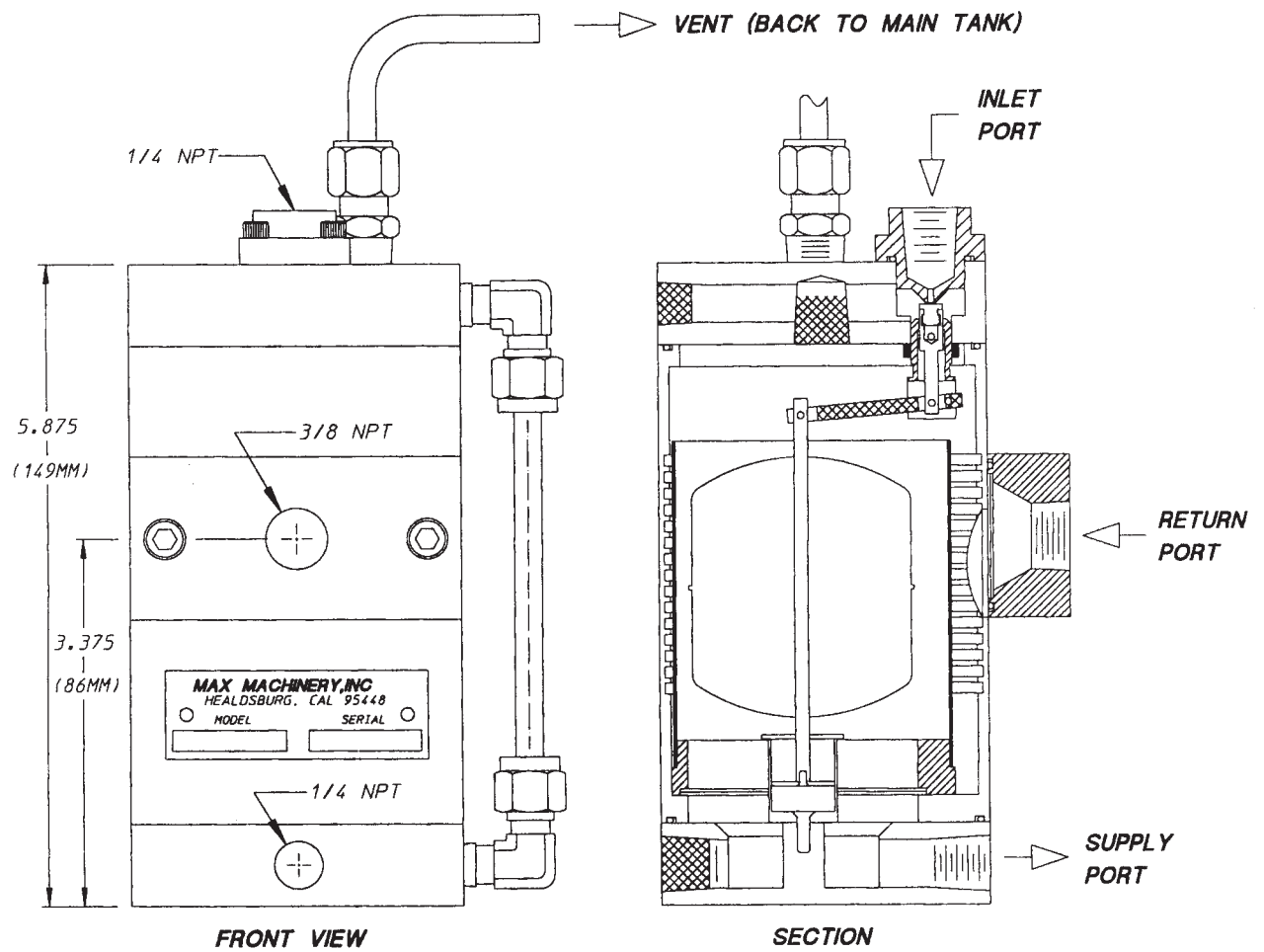

Model 370 Level Controller – Performance Curves

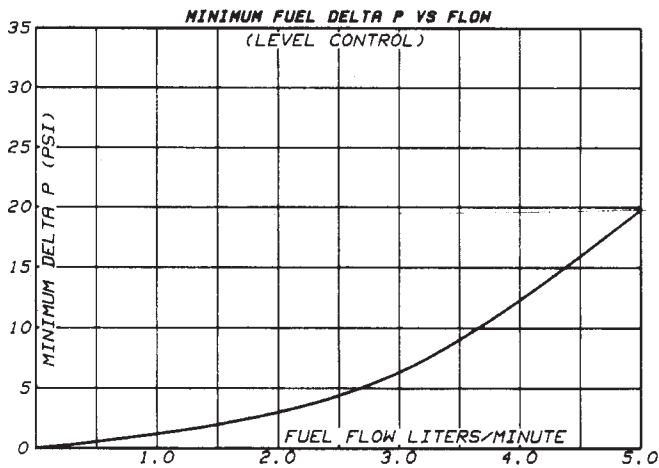
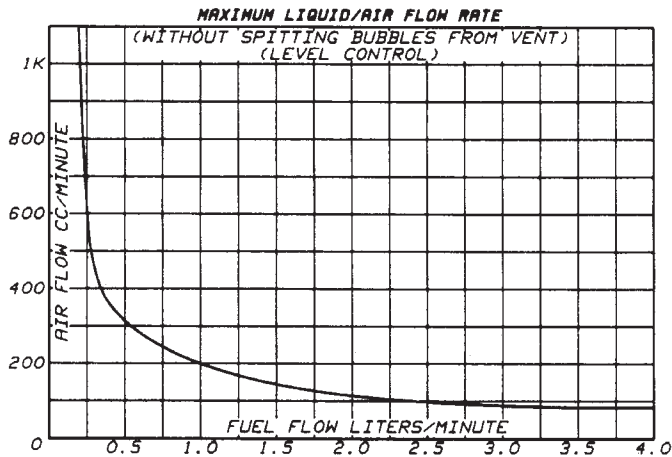
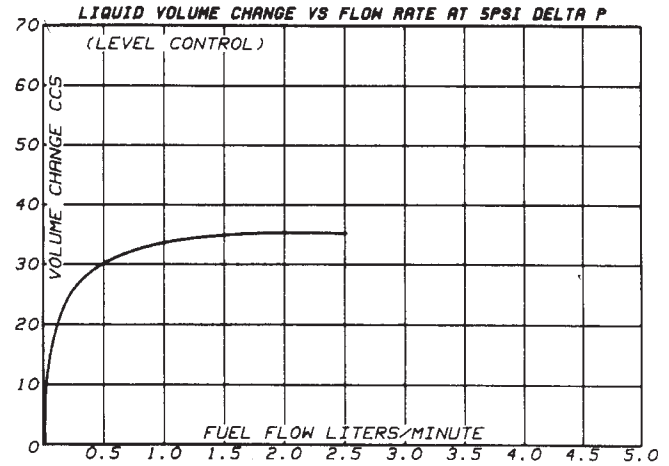
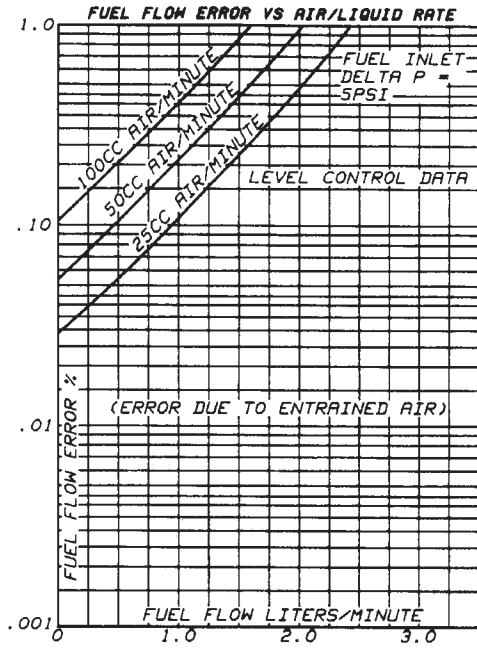

Model 372 Vapor Eliminator & Level Controller

General Description/Specifications

Materials of Construction:

Body	303 Stainless
Valve Orifice	303 Stainless
Valve Seal	Nitrile (Tan)
Float, Valve Stem & Screens	304 Stainless

Operational Limits:

Vapor Eliminator:

Max Float Bowl Pressure	75 psi (5 bar)
Max Air Eliminator Rate (Rate for gasoline equal to or greater than for Diesel)	
Diesel @ 500 cc/min	2100 cc/min
Diesel @ 1000 cc/min	1500 cc/min
Diesel @ 2000 cc/min	300 cc/min
See Graph, page 12	

Level Controller:

Max Return Rate (300 cc/min or less air)	2000 cc/min
Max Make-Up Flow Rate	See Graph, page 13

Maximum Temperature of Fuel

Gasoline	130°F (55°C)
Alcohol	140°F (60°C)
Diesel	200°F (93°C)

Model 372 Vapor Eliminator & Level Controller

Application Description

The Max Model 372 may be used as either a Vapor Eliminator or Level Controller depending on how it is installed in your fuel measurement system.

When plumbed in the Vapor Eliminator configuration, the unit removes bubbles from the fuel which would otherwise cause measurement errors as they pass through the flow meter. Bubbles may be caused by the low boiling point components in gasoline or by hot vehicle fuel lines. A design featuring a series of screens and a float mechanism effectively separates the vapors from the fuel.

When plumbed in the Level Controller configuration, the Model 372 serves as a vented, recirculation tank to collect return fuel and route it back to the supply side of the engine, while maintaining its level through a float valve that controls the fuel flow through the flow meter.

Model 372 Vapor Eliminator & Level Controller - Drawings

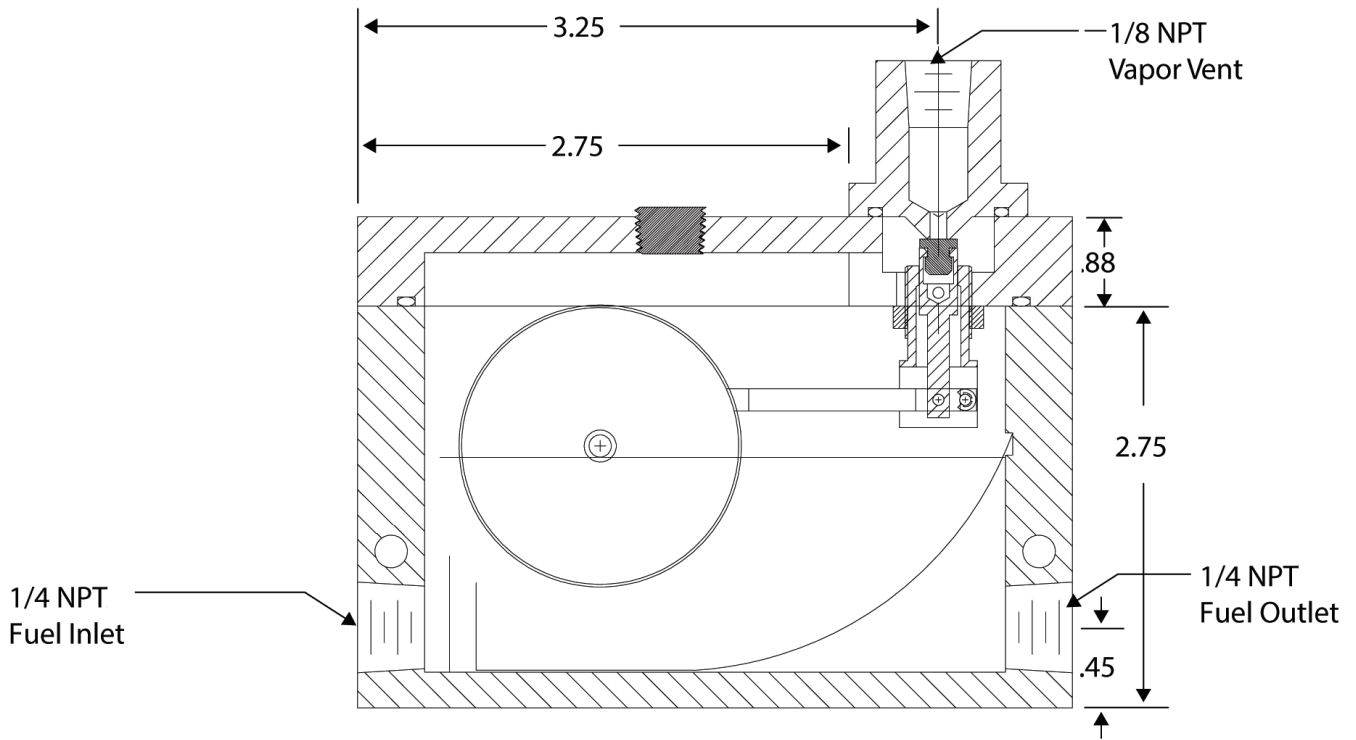
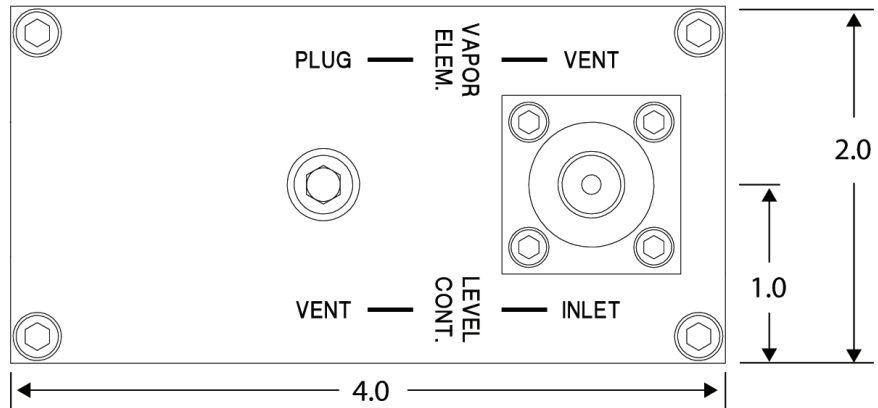

Model 372 Vapor Eliminator Mode

MAXIMUM AIR FLOW - vs. - FUEL FLOW
WITHOUT FUEL SPITTING FROM THE VAPOR VENT (WITH DIESEL)

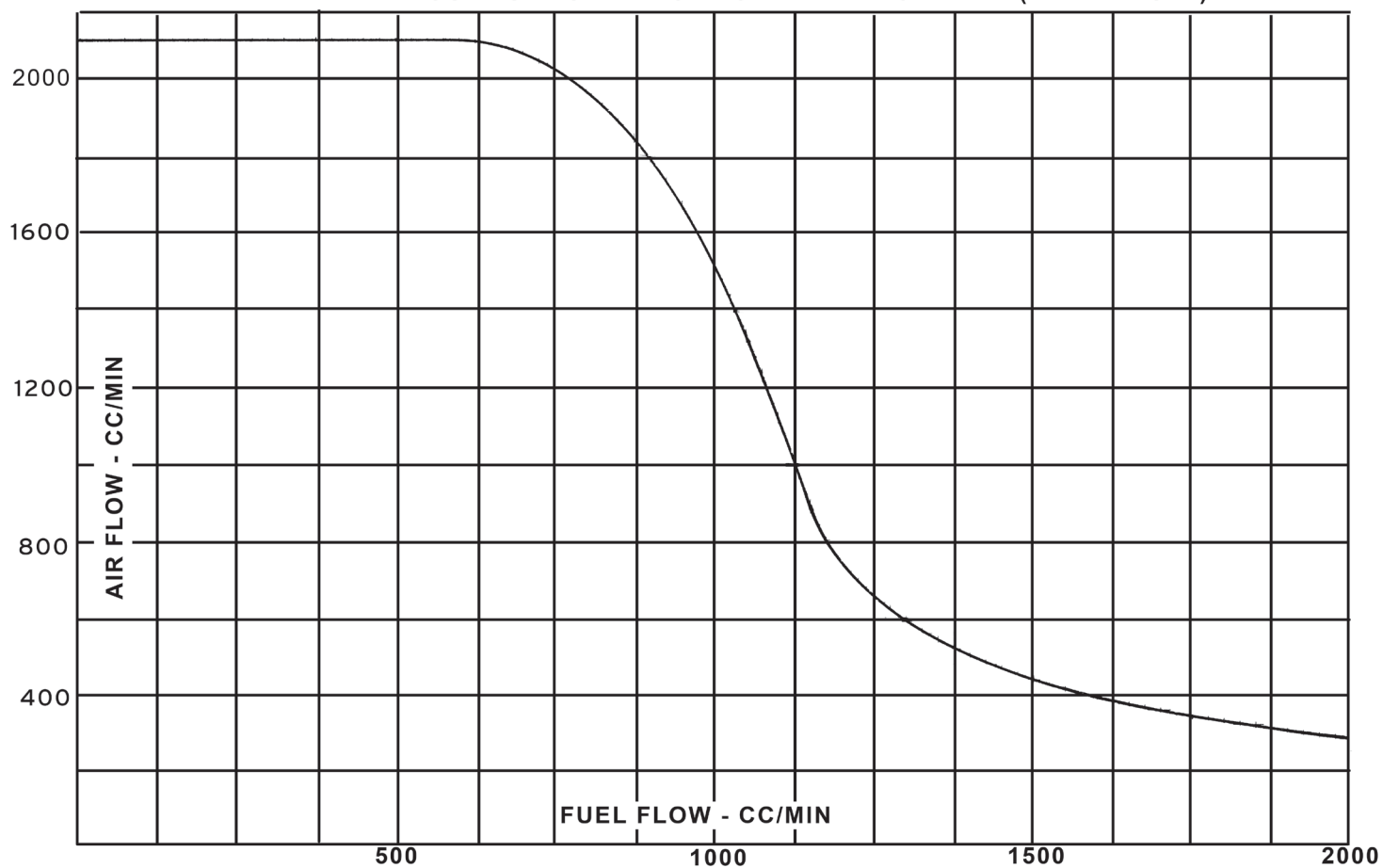

Model 372 Level Controller Mode

Flow Rate vs. Pressure for Level Controller

